

BIXOLON®

User's Manual

BK3-21

KIOSK PRINTER

Ver. 1.02

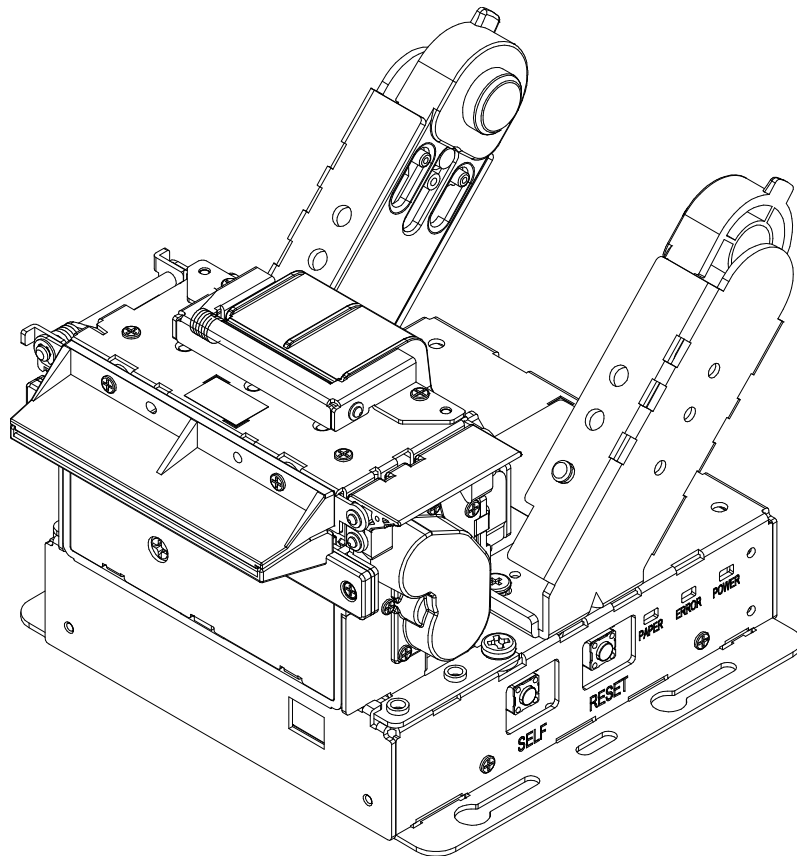

<http://www.bixolon.com>

Product Approval Sheet

Product Name	BK3-21
Manufacturer	BIXOLON
Product Specifications	BK3-21 User's Manual Rev.1.02
Customer	
Approved Date	
Signature	

※ Be sure to read the warnings and cautions (⚠) in the instruction manual.

Introduction

BK3-21 printers have been designed to be connected to various types of kiosk system.

※ The main features of the printer

1. KIOSK PRINTER
2. Thermal Receipt Printer
3. Maximum 250mm/s printing speed
4. External size
 - Diameter Φ 80: 109 x 130 x 91 (W x D x H)
 - Diameter Φ 102: 109 x 137 x 99 (W x D x H)
 - Diameter Φ 120: 109 x 144 x 105 (W x D x H)
5. Serial/USB communication
6. Equipped with data buffer (receives print data even while printing)
7. Can print a range of barcodes
8. Range of printing density selectable (controlled with virtual memory switch management)

It is advisable to read the contents of this manual carefully before using the printer for the first time.

※ Use only authorized supplies that can be trusted!

- We are not responsible for quality and service for damage caused by the use of unauthorized products (or recycled ones).

Safety Information

 **Warning:** Warnings must be heeded carefully in order to prevent serious physical harm.

 **Caution:** Cautions must be heeded in order to prevent minor injuries, equipment damage, or data loss.

Table of Contents

1. Installing Printer and Getting Started	5
1-1 Unpacking	5
1-2 Interface and Power port	6
1-2-1 Serial Interface Signal Description(DSUB 9P Type)	7
1-2-2 Serial Interface Signal Description(Connector 5P Type)	7
1-2-3 USB Interface Signal Description(Connector 4P Type)	7
1-2-4 Power Signal Description(Connector 2P Type)	7
1-3 Power Supply Port and Connecting Power Supply	8
1-4 Reconfiguration of Printer	10
1-4-1 DIP Switch 1	10
1-4-2 MSW (Memory Switch)	11
1-5 Product Part Names	17
1-6 Installing & Replacing Paper	18
1-7 Adjusting Near End Sensor	21
1-8 Removing Paper Jam	22
1-9 Using Printer Functions	23
2. Self-Test	24
3. Automatic calibration of Black-mark sensor	27
4. Cleaning Printer	28
5. Specifications	29

1. Installing Printer and Getting Started

1-1 Unpacking

- Check the following contents list, and contact your dealer for assistance if any item is missing or incorrect.

- Product

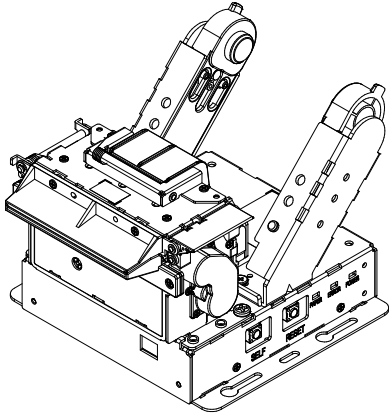

BK3-21

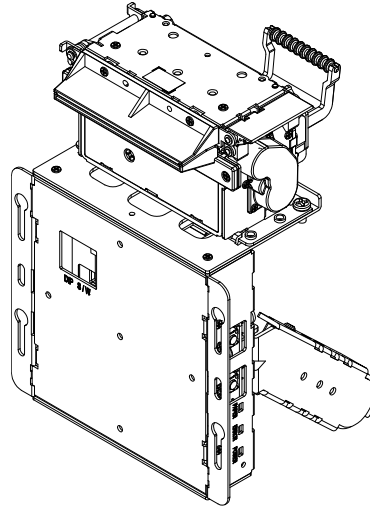

BK3-21V
(Vertical Type)

- Optional Components

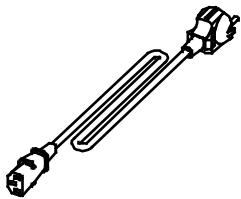

Power Cord

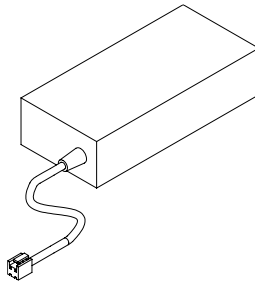

AC/DC Adaptor(2P)

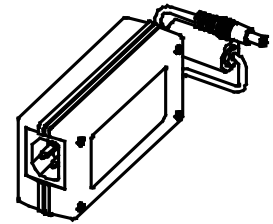

AC/DC Adaptor(DC-Jack)

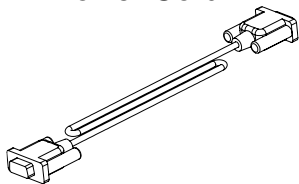

Serial Cable
(9pin - 9pin)

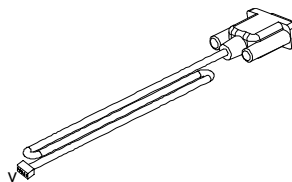

Connector Cable
(5pin - 9pin)

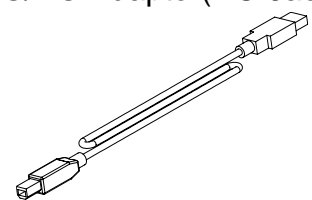

USB A-B Cable

1-2 Interface and Power port

- Connect the printer to the host computer using the right interface cable that complies with the specifications of the interface

1. BK3-21a Model: DC Jack Power + Serial Dsub 9P + USB B

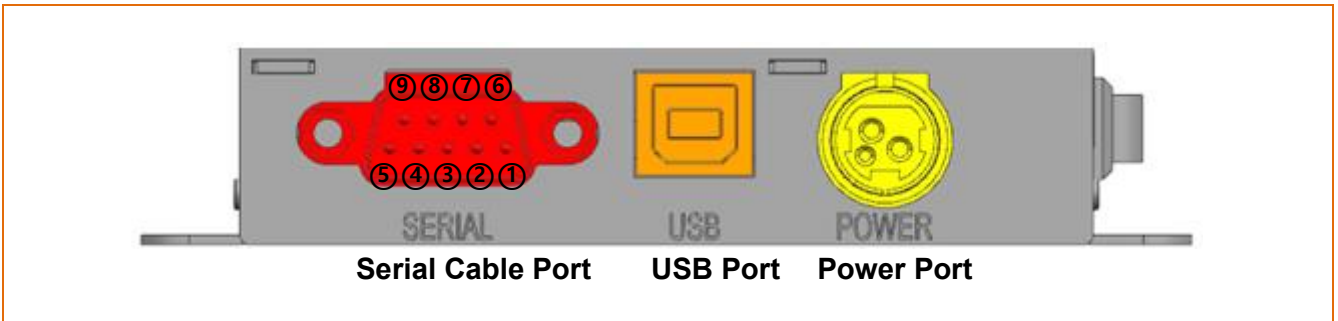

2. BK3-21b Model: 2P Connector Power + Serial Dsub 9P + USB B

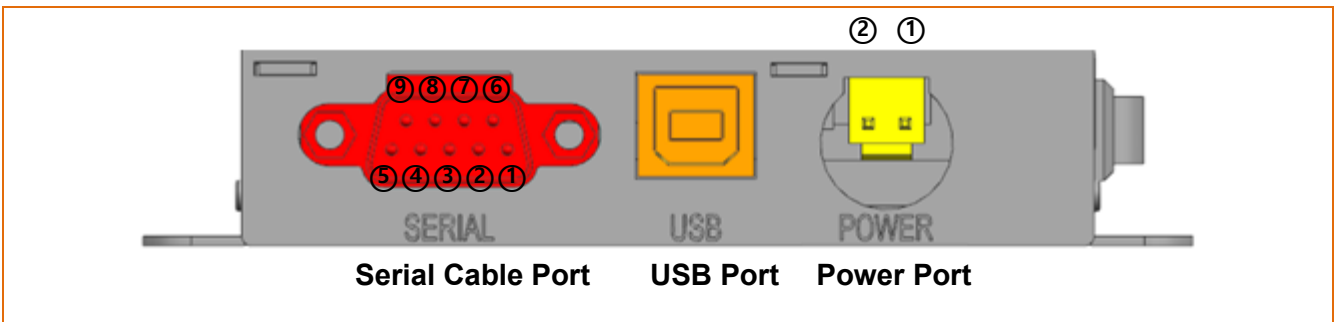

3. BK3-21c Model: DC Jack Power + Serial 5P Connector + USB B

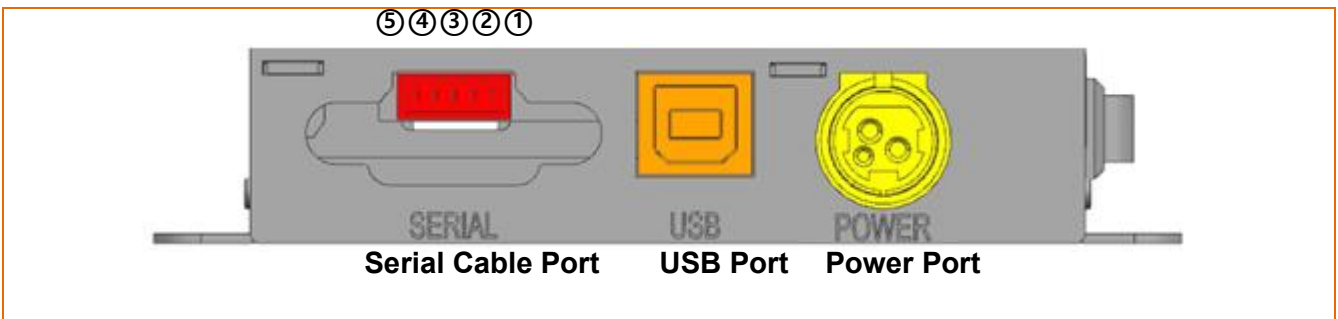

4. BK3-21d Model: 2P Connector Power+ Serial 5P Connector + USB B

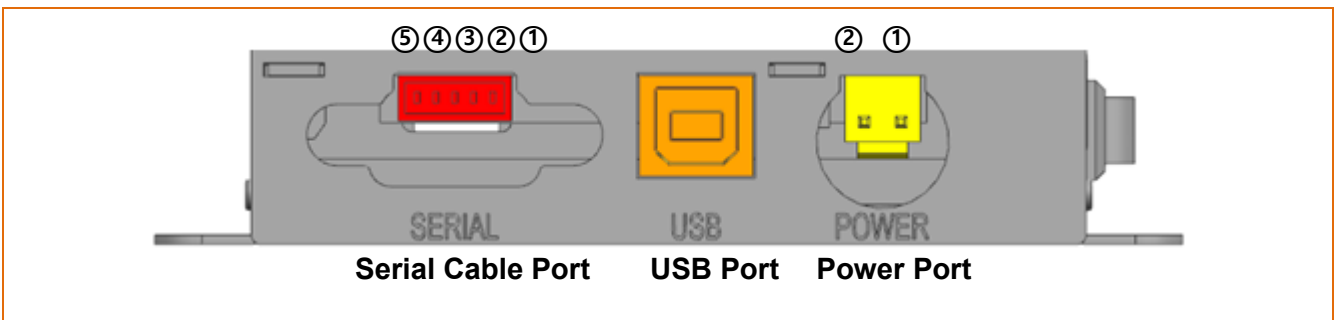

5. BK3-21e Model: 2P connector Power + Serial 5P Connector + USB 4P Connector

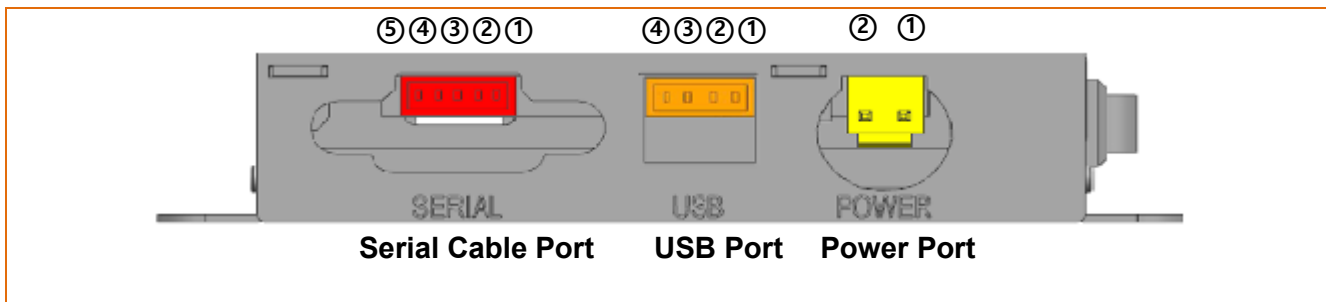

1-2-1 Serial Interface Signal Description(DSUB 9P Type)

Pin No	Signal	Direction	Function
1	NC	-	-
2	RxD	Input	Receive Data
3	TxD	Output	Transmit Data
4	DTR	Output	Data Terminal Ready
5	GND	-	Signal Ground
6	DSR	Input	Data Set Ready
7	RTS	Output	Ready To Send
8	CTS	Input	Clear To Send
9	NC	-	-

1-2-2 Serial Interface Signal Description(Connector 5P Type)

(Connector Part Number: 20017WR-05A00, Manufacturer: Yeonho Electronics)

Pin No	Signal	Direction	Function
1	CTS	Input	Clear To Send
2	RxD	Input	Receive Data
3	TxD	Output	Transmit Data
4	RTS	Output	Ready To Send
5	GND	-	Signal Ground

1-2-3 USB Interface Signal Description(Connector 4P Type)

(Connector Part Number: 20017WR-04, Manufacturer: Yeonho Electronics)

Pin No	Signal	Function
1	D-	Differential Data Line
2	D+	Differential Data Line
3	GND	Signal Ground
4	VBUS	Host Power: DC5[V] / 500[mA]

1-2-4 Power Signal Description(Connector 2P Type)

(Connector Part Number: YH396-02, Manufacturer: Yeonho Electronics)

Pin No	Signal	Function
1	VCC	Power(24Vdc)
2	GND	Frame Ground

1-3 Power Supply Port and Connecting Power Supply

- 1) Make sure the product is turned off before connecting the power supply.
- 2) Connect the power cable with the flat side pointing downward of the printer, as shown in the diagram below.

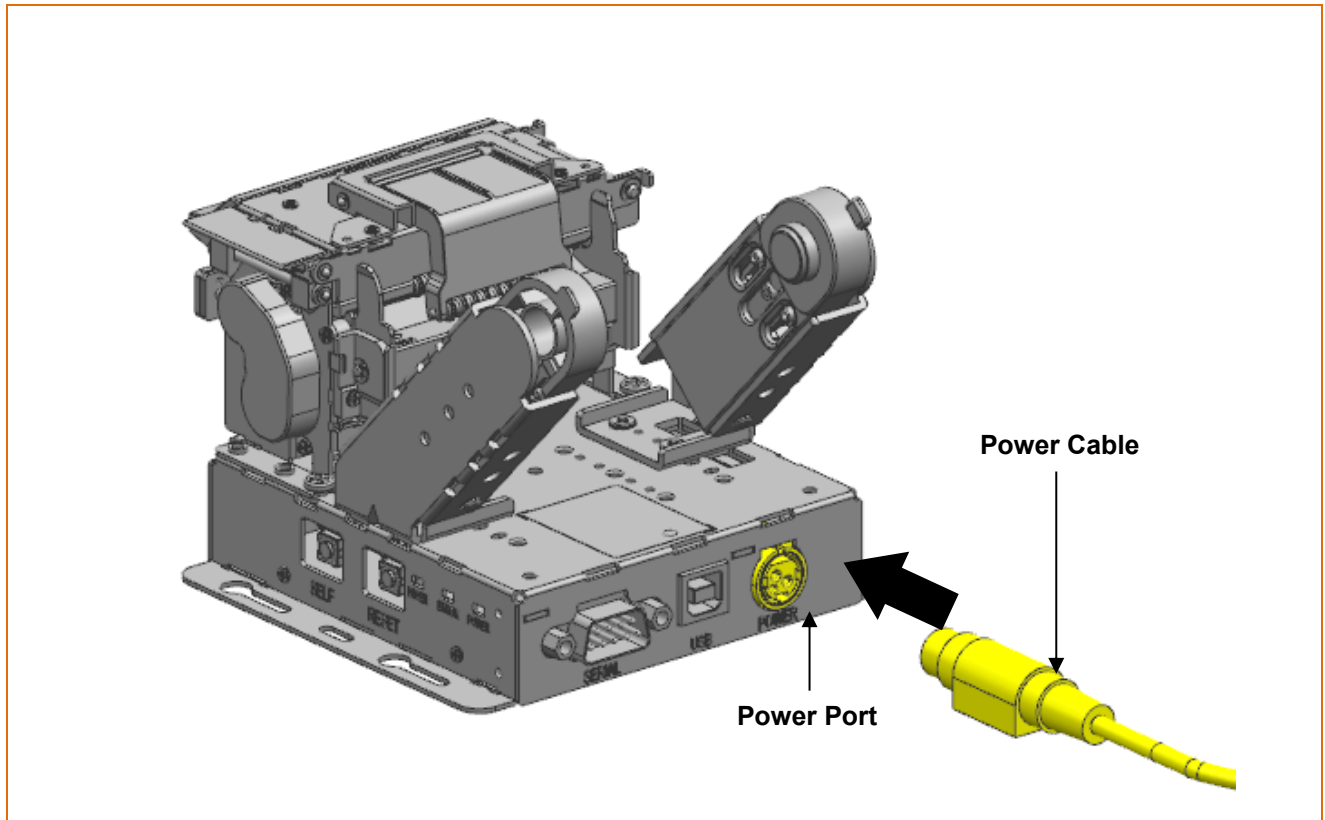

- Only use a power supply provided by Bixelon. Bixelon shall bear no responsibility for damage caused by using a third-party power supply.
- Check the power supply's label to check its electronic specs.
- When removing the power supply, make sure you have a firm grasp of the plug terminal of the power cable and the printer and pull horizontally.
- When connecting or disconnecting power, make sure to remove the power supply from the power outlet before removing.
- Pay attention to the direction in which you insert the power cable.

 **Caution**

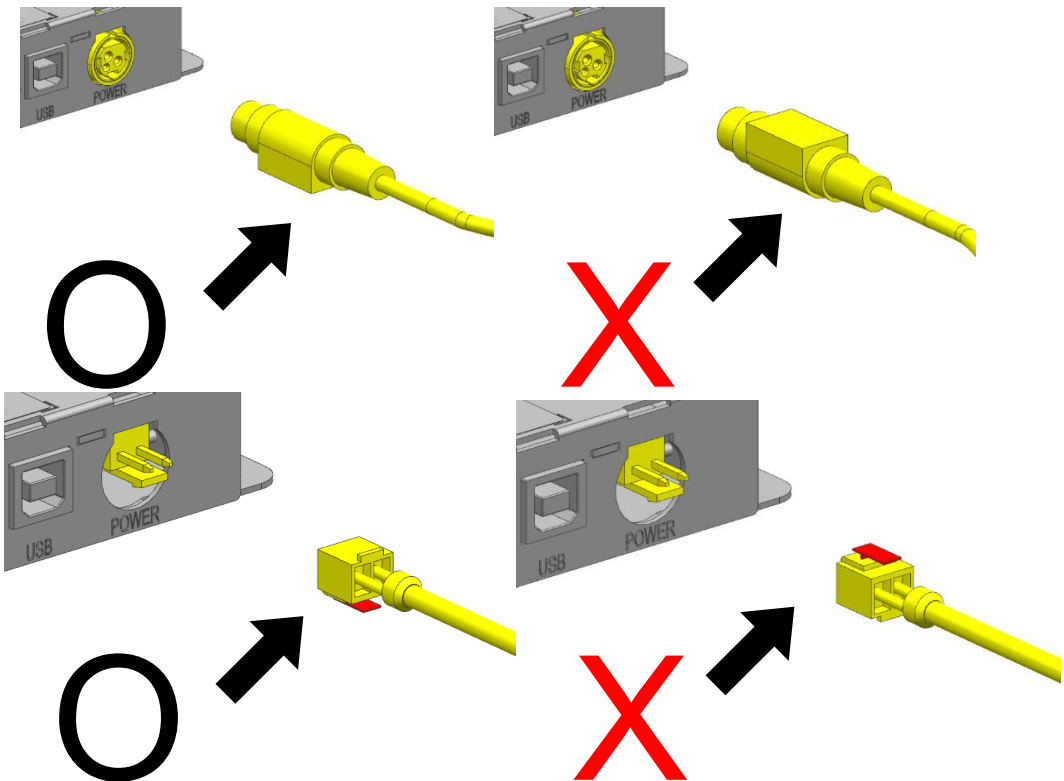

 **Warning**

Do not connect a voltage out of the specifications of the power supply. It can cause damage to the product or a fire.

1-4 Reconfiguration of Printer

- This product supports dip switch. In order to change the product settings, change the dip switch setting or use the virtual memory switch utility. Use virtual memory switch management function for self-diagnosis.

1-4-1 DIP Switch 1

Switch	Function	ON	OFF	Default
1-1	Baud rate selection (bps)	* Refer to following Table 1		OFF
1-2				OFF
1-3	-	-	-	OFF
1-4	Black mark mode	Enable	Disable	OFF

* Table 1 – Baud rate (bps) selection

Baud rate (bps)	1-2	1-1	Default
115,200	OFF	OFF	115,200
38,400	OFF	ON	
19,200	ON	OFF	
9,600	ON	ON	

- * Flow control, data length, and parity bits can be changed via virtual memory switch settings (Refer to MSW 8).

1-4-2 MSW (Memory Switch)**1) MSW 1**

Switch	Function	ON	OFF	Default
1-1	Select print speed	* Refer to following Table 2		OFF
1-2				OFF
1-3				OFF
1-4	-	-	-	OFF
1-5	-	-	-	OFF
1-6	Select print density	* Refer to following Table 3		OFF
1-7				OFF
1-8				OFF

*** Table 2 – Print speed selection**

Print speed	1-3	1-2	1-1	Default
250mm/s	OFF	ON	OFF	200mm/s
230mm/s	OFF	OFF	ON	
200mm/s	OFF	OFF	OFF	
170mm/s	OFF	ON	ON	
150mm/s	ON	OFF	OFF	
130mm/s	ON	OFF	ON	
120mm/s	ON	ON	OFF	
100mm/s	ON	ON	ON	

*** Table 3 – Print Density Selection**

Print Density	1-8	1-7	1-6	Remark
Density Level 5	ON	OFF	ON	Dark
Density Level 4	ON	OFF	OFF	
Density Level 3	OFF	OFF	OFF	Default
Density Level 2	OFF	OFF	ON	
Density Level 1	OFF	ON	OFF	Light

2) MSW 2

Switch	Function	ON	OFF	Default
2-1	Specification for destination	Double byte country	Single byte country	OFF
2-2	-	-	-	OFF
2-3	Code page selection	* Refer to following Table 4		OFF
2-4				OFF
2-5				OFF
2-6				OFF
2-7				OFF
2-8				OFF

* Table 4 – Code page selection

2-8	2-7	2-6	2-5	2-4	2-3	Character Table	
OFF	OFF	OFF	OFF	OFF	OFF	Page 0	437 (USA, Standard Europe)
OFF	OFF	OFF	OFF	ON	OFF	Page 1	Katakana
OFF	OFF	OFF	ON	OFF	OFF	Page 2	850 (Multilingual)
OFF	OFF	OFF	ON	ON	OFF	Page 3	860 (Portuguese)
OFF	OFF	ON	OFF	OFF	OFF	Page 4	863 (Canadian-French)
OFF	OFF	ON	OFF	ON	OFF	Page 5	865 (Nordic)
OFF	OFF	ON	ON	OFF	OFF	Page 16	1252 (Latin I)
OFF	OFF	ON	ON	ON	OFF	Page 17	866 (Cyrillic #2)
OFF	ON	OFF	OFF	OFF	OFF	Page 18	852 (Latin 2)
OFF	ON	OFF	OFF	ON	OFF	Page 19	858 (Euro)
OFF	ON	OFF	ON	OFF	OFF	Page 21	862 (Hebrew DOS code)
OFF	ON	OFF	ON	ON	OFF	Page 22	864 (Arabic)
OFF	ON	ON	OFF	OFF	OFF	Page 23	Thai42
OFF	ON	ON	OFF	ON	OFF	Page 24	1253 (Greek)
OFF	ON	ON	ON	OFF	OFF	Page 25	1254 (Turkish)
OFF	ON	ON	ON	ON	OFF	Page 26	1257 (Baltic)
ON	OFF	OFF	OFF	OFF	OFF	Page 27	Farsi
ON	OFF	OFF	OFF	ON	OFF	Page 28	1251 (Cyrillic)
ON	OFF	OFF	ON	OFF	OFF	Page 29	737 (Greek)
ON	OFF	OFF	ON	ON	OFF	Page 30	775 (Baltic)
ON	OFF	ON	OFF	OFF	OFF	Page 31	Thai14
ON	OFF	ON	OFF	ON	OFF	Page 32	Hebrew Old code
ON	OFF	ON	ON	OFF	OFF	Page 33	1255 (Hebrew New code)
ON	OFF	ON	ON	ON	OFF	Page 34	Thai11
ON	ON	OFF	OFF	OFF	OFF	Page 35	Thai18
ON	ON	OFF	OFF	ON	OFF	Page 36	855 (Cyrillic)
ON	ON	OFF	ON	OFF	OFF	Page 37	857 (Turkish)
ON	ON	OFF	ON	ON	OFF	Page 38	928 (Greek)
ON	ON	ON	OFF	OFF	OFF	Page 39	Thai16
ON	ON	ON	OFF	ON	OFF	Page 40	1256 (Arabic)
ON	ON	ON	ON	OFF	OFF	Page 41	1258 (Vietnam)
ON	ON	ON	ON	ON	OFF	Page 42	Khmer (Cambodia)
OFF	OFF	ON	OFF	OFF	ON	Page 47	1250 (Czech)
OFF	OFF	ON	ON	ON	ON	Page 49	TCVN-3
OFF	ON	OFF	OFF	OFF	ON	Page 50	TCVN-3 (Capital)
OFF	ON	OFF	OFF	ON	ON	Page 51	VISCII

3) MSW 3

Switch	Function	ON	OFF	Default
1	Select emulation	* Refer to following Table 5		OFF
2				OFF
3				OFF
4	-	-	-	OFF
5	Printing mode for Thai character	3 PASS	1 PASS	OFF
6~8	-	-	-	OFF

* Table 5 – Emulation selection

Emulation	3-3	3-2	3-1	Remark
Emulation 1	OFF	OFF	OFF	
Emulation 2	OFF	OFF	ON	BXL / POS
Emulation 3	OFF	ON	OFF	
Emulation 4	OFF	ON	ON	
Emulation 5	ON	OFF	OFF	

* Supports all BIXOLON software only when set to Emulation 2 (BXL / POS).

4) MSW 4

Switch	Function	ON	OFF	Default
1	Swap font B and C	Enable	Disable	OFF
2	Printer buffer initialization	Enable	Disable	OFF
3	Single byte font selection (Default font)	* Refer to following Table 6		OFF
4				OFF
5~8	-	-	-	OFF

* Table 6 – Single byte Font Selection

Single byte font selection	4-4	4-3	Default
Font A (12 x 24)	OFF	OFF	Font A
Font B (9 x 17)	OFF	ON	
Font C (9 x 24)	ON	OFF	
-	ON	ON	

* The printer buffer initialization function works when the printer cover is opened and closed.

5) MSW 5

Switch	Function	ON	OFF	Default
1	Auto cutter selection	* Refer to following Table 7		OFF
2				OFF
3	Paper save mode	* Refer to following Table 8		OFF
4				OFF
5	Paper save mode cutting correction	Enable	Disable	OFF
6	Auto line feed (CR mode)	Enable (LF)	Disable (Ignore)	OFF
7	-	-	-	OFF
8	Near-end sensor	Disable	Enable	OFF

* Table 7 – Auto Cutter Selection

Auto Cutter Selection	5-2	5-1	Remark
Full cut	OFF	OFF	Default
Partial cut	OFF	ON	
Programmable cut	ON	OFF	
No cut	ON	ON	

* Programmable cut is operated according to the parameters of GS V command, while others operate as partial cut.

* Table 8 – Paper save mode

Paper save mode	5-4	5-3	Remark
Disable	OFF	OFF	Default
Level 1	OFF	ON	
Level 2	ON	OFF	
Level 3	ON	ON	

6) MSW 6

Switch	Function	ON	OFF	Default
1~8	-	-	-	OFF

7) MSW 7

Switch	Function	ON	OFF	Default
1	Print width selection	* Refer to following Table 9		OFF
2				OFF
3	-	-	-	OFF
4	-	-	-	OFF
5	-	-	-	OFF
6	-	-	-	OFF
7	black mark sensor selection	Right	Left	OFF
8	-	-	-	OFF

* Black mark sensor selection applies only when DIP switches 1-4 are ON.

* Select sensor from paper exit as standard.

* Table 9 – Print width selection

Print width	7-2	7-1	Default
54mm (432dot)	OFF	OFF	54mm
48mm (384dot)	OFF	ON	
12mm (96dot)	ON	OFF	

8) MSW 8

Switch	Function	ON	OFF	Default
1	Data length	7 bit	8 bit	OFF
2	Parity check	YES	NO	OFF
3	Parity selection	EVEN	ODD	OFF
4	Data receive error	Ignore	Print “?”	OFF
5	Baud rate selection	* Refer to following Table 10		OFF
6				OFF
7				OFF
8	Serial interface selection	Memory Switch	DIP Switch	OFF

* The memory switch setting for 8-5 to 7 (Baud rate selection) applies only when memory switch 8-8 is ON.

* The setting for DIP switch is not considered when memory switch 8-8 is ON.

* Table 10 - Baud rate selection

Baud rate	8-7	8-6	8-5	Default
115,200bps	OFF	OFF	OFF	115,200bps
57,600bps	OFF	OFF	ON	
38,400bps	OFF	ON	OFF	
19,200bps	OFF	ON	ON	
9,600bps	ON	OFF	OFF	
4,800bps	ON	OFF	ON	
2,400bps	ON	ON	OFF	
115,200bps	ON	ON	ON	

9) MSW 9

Switch	Function	ON	OFF	Default
1	Serial communication flow control	* Refer to following Table 11		OFF
2				OFF
3~8	-	-	-	OFF

* Table 11 - Serial communication flow control

Serial communication flow control	9-2	9-1	Default
Hardware(DTR/DSR)	OFF	OFF	Hardware (DTR/DSR)
Software(XON/XOFF)	OFF	ON	
None	ON	OFF	
Hardware(DTR/DSR)	ON	ON	

10) MSW 10

Switch	Function	ON	OFF	Default
1~8	-	-	-	OFF

11) MSW 11

Switch	Function	ON	OFF	Default
1~8	-	-	-	OFF

12) MSW 12

Switch	Function	ON	OFF	Default
1	Select double byte country	* Refer to following Table 12		OFF
2				OFF
3				OFF
4~8	-	-	-	OFF

* Table 12 - Select double byte country



Select double byte country	12-3	12-2	12-1	Remark
STD	OFF	OFF	OFF	Single byte font
KOR	OFF	OFF	ON	KS5601
CHN	OFF	ON	OFF	BIG5 or GB2312
JPN	OFF	ON	ON	SHIFT-JIG

13) MSW 13

Switch	Function	ON	OFF	Default
1~8	-	-	-	OFF

14) MSW 14

Switch	Function	ON	OFF	Default
1~8	-	-	-	OFF

 Note	<ul style="list-style-type: none"> - Use unified utility or self-test mode to change the virtual memory switch setting. - Refer to the utility and service manual for more information.
 Caution	<ul style="list-style-type: none"> - Make sure to turn the printer off and on again after using the virtual memory switch utility to adjust the settings of the product. - To change the DIP switch setting, turn off the printer power. Changing the DIP switch setting while the power is on may cause a short circuit and result in printer malfunction. - Supports all BIXOLON software only when set to Emulation 2 (BXL / POS).

1-5 Product Part Names

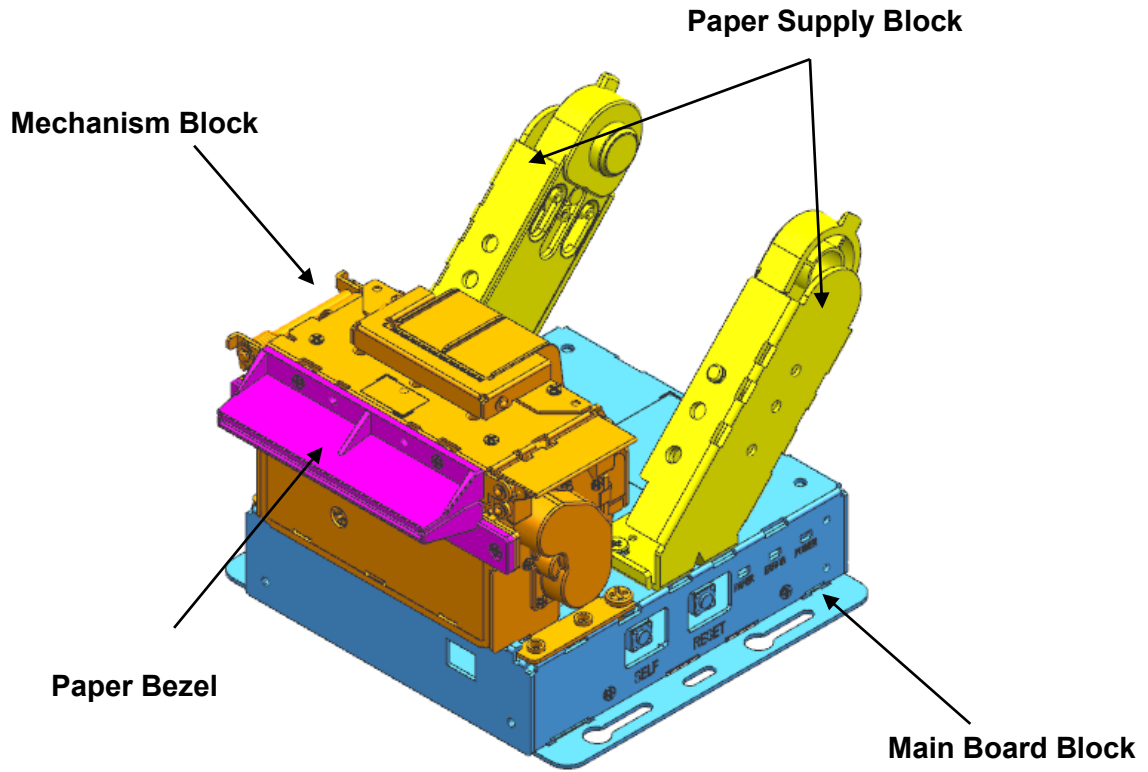

Horizontal Standard Type

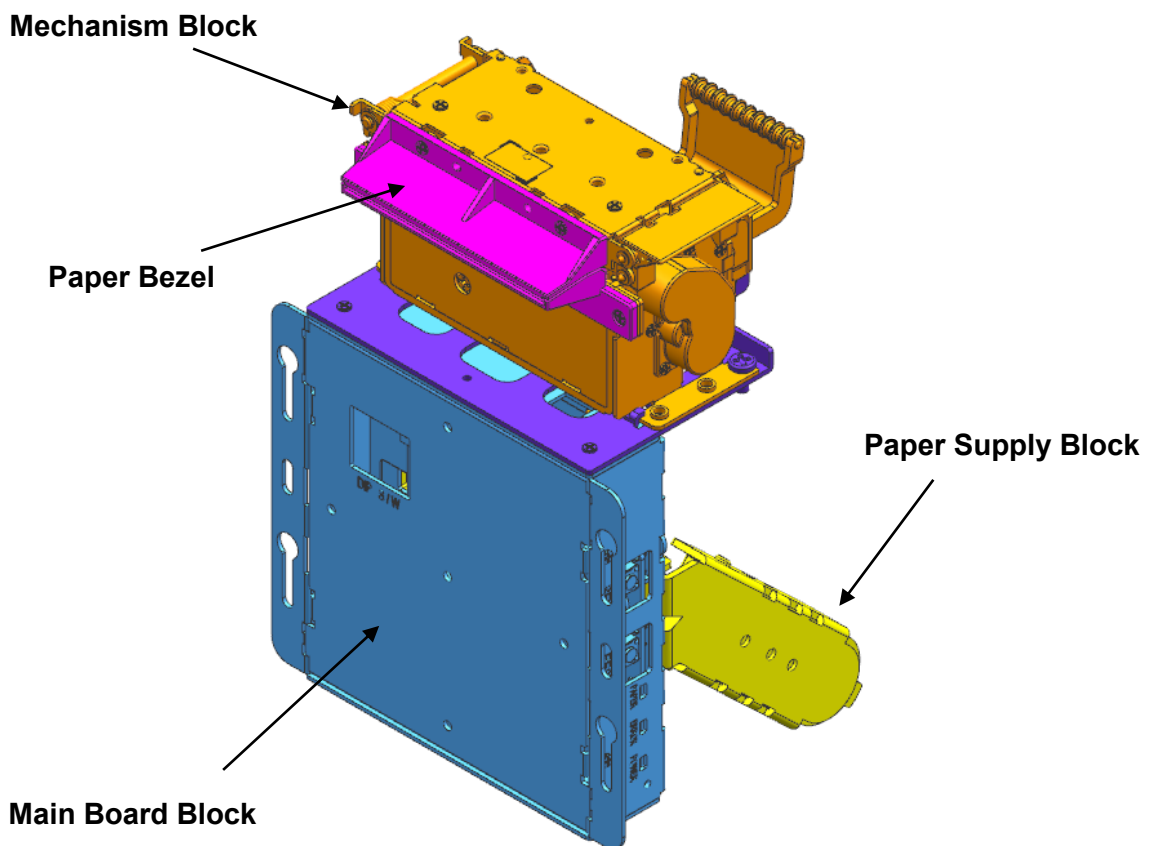

Vertical Type

1-6 Installing & Replacing Paper

1) Open the print cover by pulling the Lever-Lock.

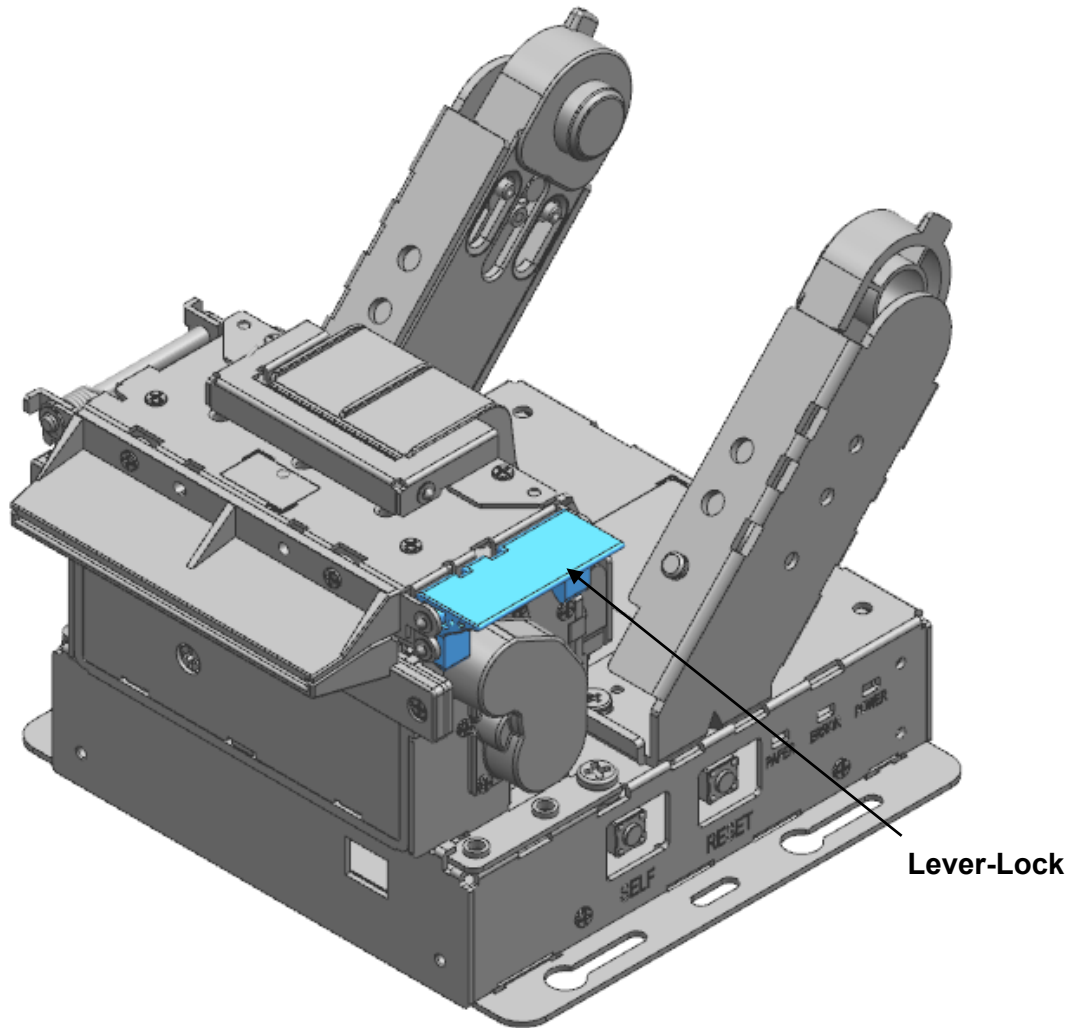

Do not open the print cover while the printer is operating, otherwise the printer may be damaged.

2) Install and change paper by adjusting the holder-paper as shown below.

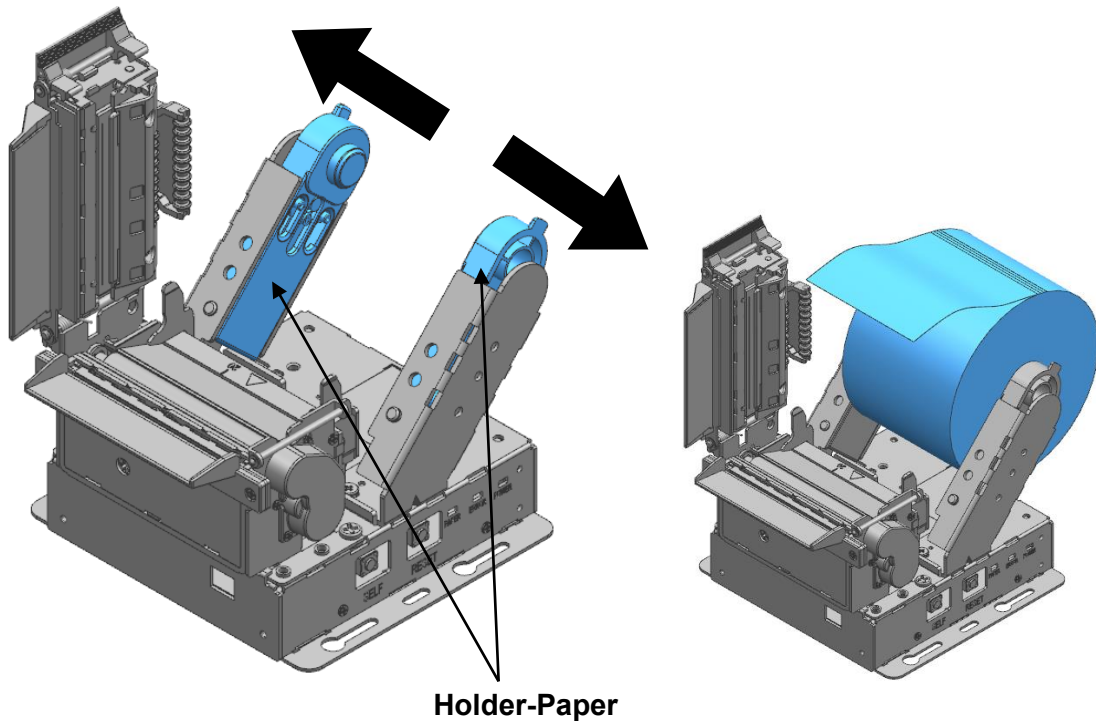

Check the orientation of the roll paper when inserting it into the printer.

 **Caution**

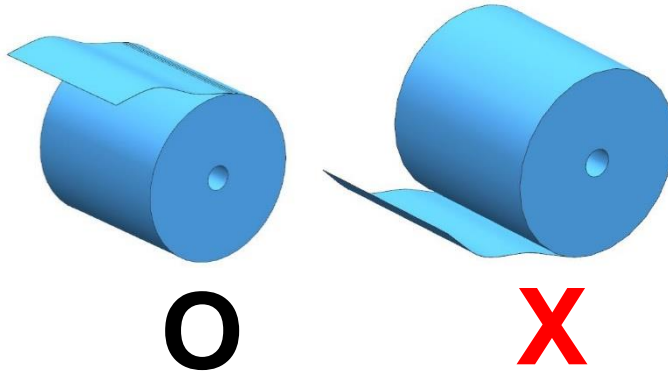

3) Pull out a small amount of paper as shown in the picture, and close the cover.

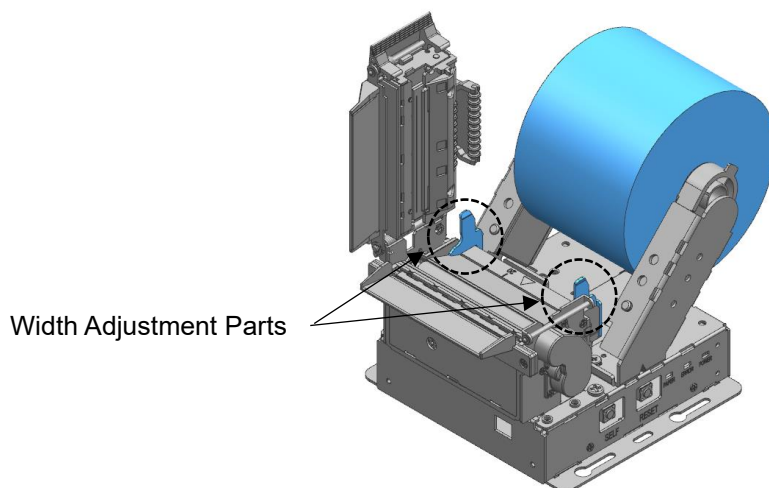
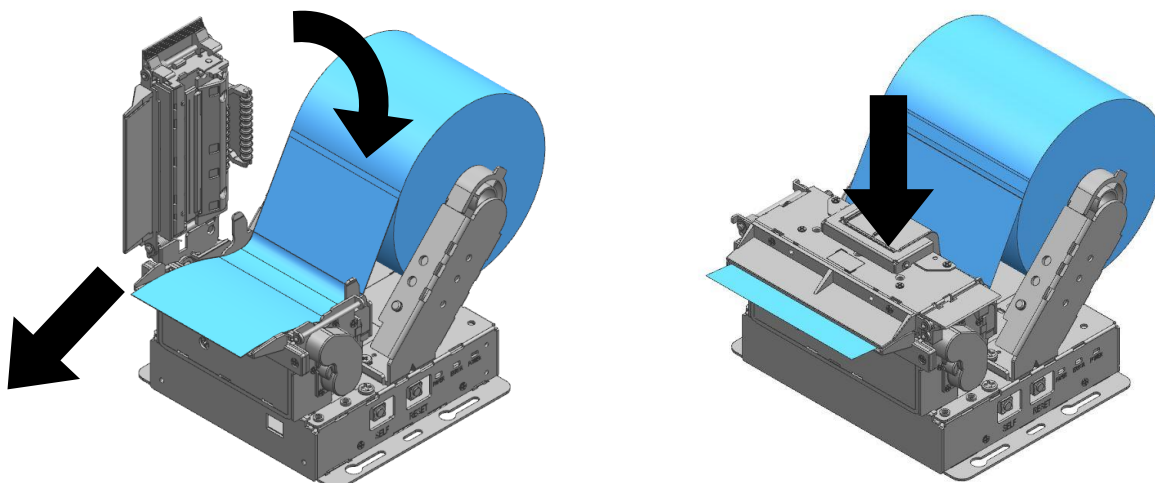

Width Adjustment Parts

 **Caution**

- When closing the cover, hold down the center of printer cover firmly so that paper roll is loaded correctly.
- Use paper suitable for the standards.
- Change paper when the printer does not receive data. Otherwise, data loss can be caused.
- If printing on the side does not work, adjust the Width Adjustment Parts to the left or right.

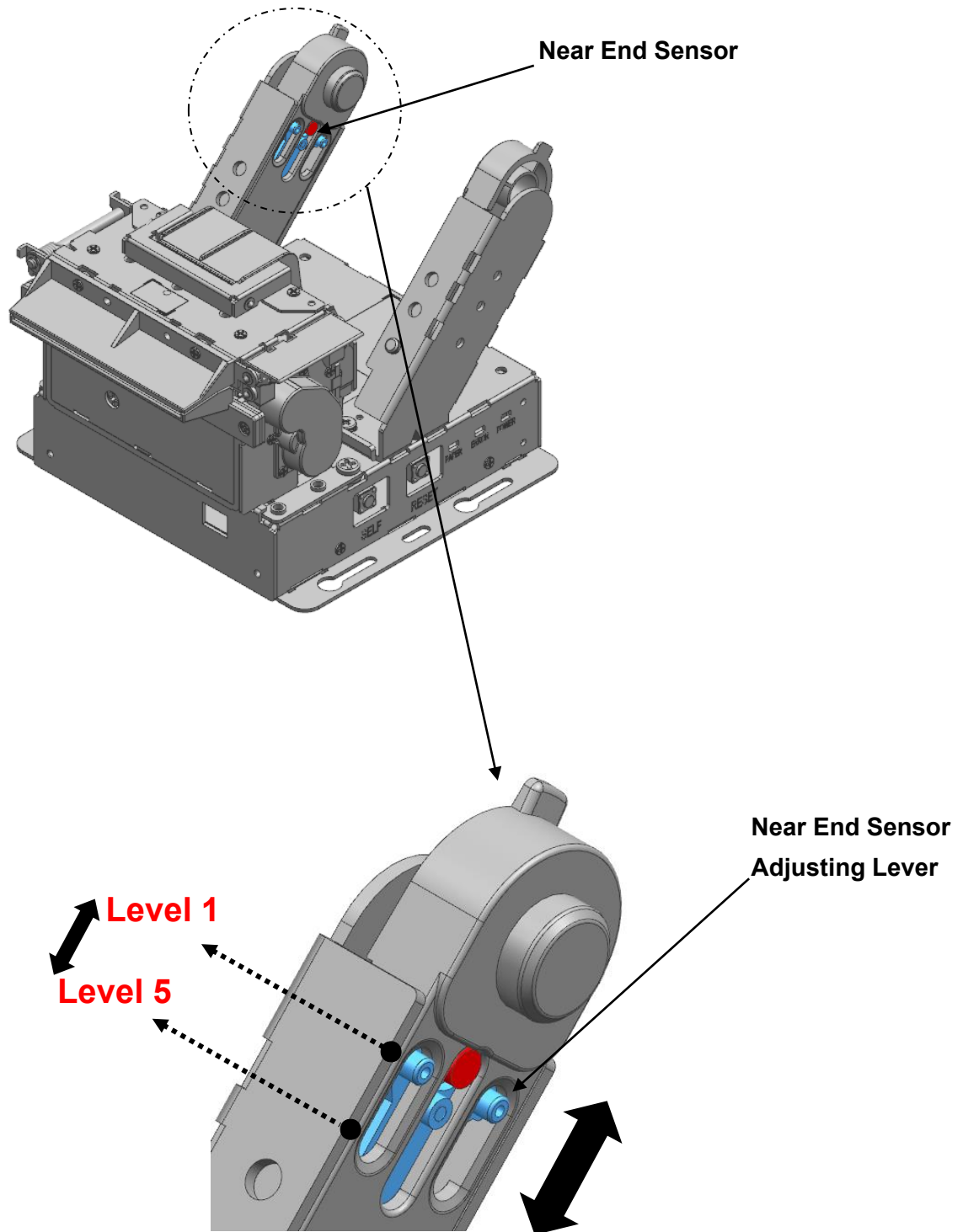

1-7 Adjusting Near End Sensor

- As each paper tube has a different point of detecting near end sensor, use the printer by adjusting the near end level. When adjusting the position of near end sensor, move the lever in the direction of the arrow. The adjustment level is composed of five levels; adjust the level to level 5 for a bigger outer diameter, while moving to level 1 for a smaller outer diameter (Refer to the figure below).



1-8 Removing Paper Jam

- 1) If paper jam is occurred, power off the printer, open the cover using the lever-lock and remove jammed paper. If cutter does not return to original position, act as follows.
- 2) Turn the printer off.
- 3) As shown in the figure below, turn the gear part by using a screwdriver and add a projected blade.
- 4) Turn the printer on and use it.

 Caution	- Placing your hand above the printer outlet may cause a paper jam. - If the cover will not open due to a minor paper jam, turning the power OFF → ON will automatically return the blade to its original position.
 Warning	If the cover does not open, do not forcibly open it. It may result in poor paper cutting or printer damage.

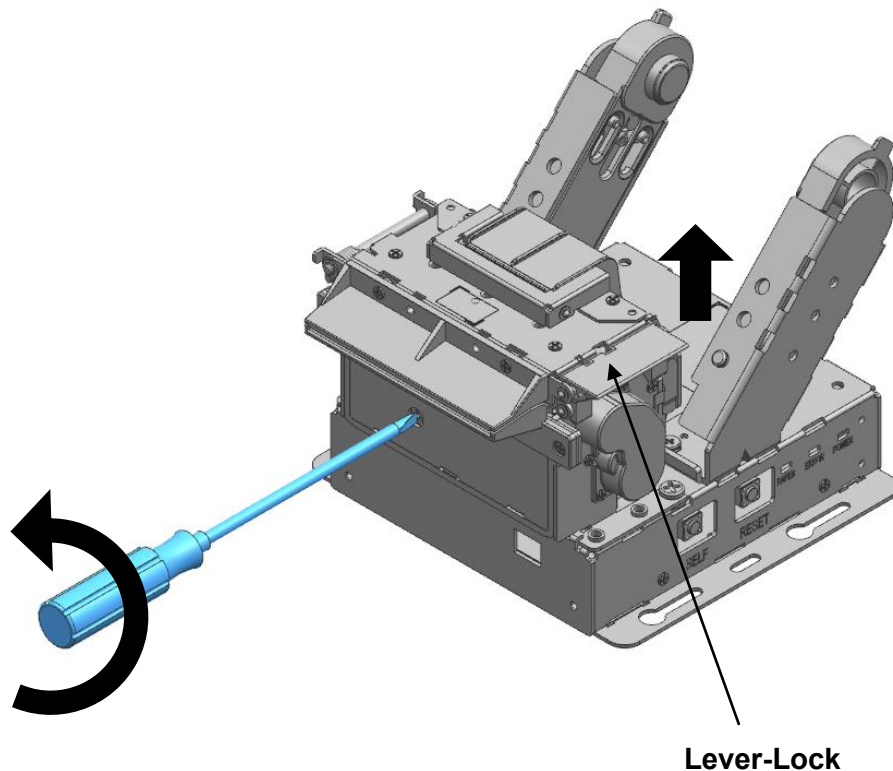

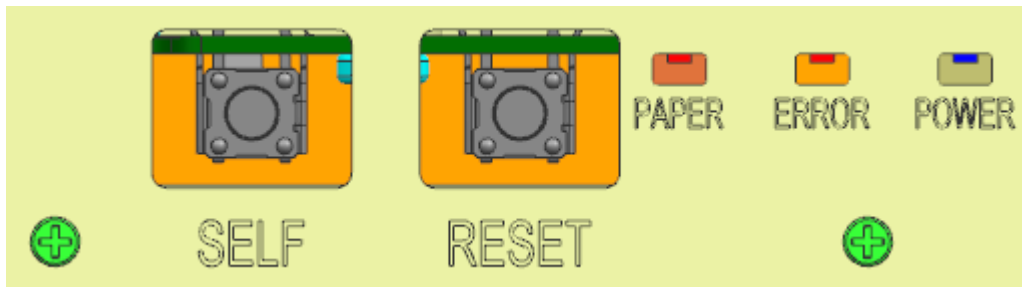
1-9 Using Printer Functions

- POWER
Green light will be on when the power is supplied to printer.
- ERROR
Red light will be on in various error conditions (e.g. no paper, cover open, etc.)
- PAPER
Red LED will be lit when the paper roll is running low. The LED keeps blinking when the printer is in self-test standby mode or macro execution standby mode.
- RESET
Press the RESET button once to restart the printer.
- SELF
Press the SELF button once to conduct self-test printing.
If necessary, press the SELF button and conduct setting virtual memory or hexadecimal dump mode after checking the printed contents for self-testing.

2. Self-Test

• The self-test checks whether the printer has any problems. If the printer does not function properly, contact your dealer. The self-test procedure is as follows:

- 1) Make sure paper roll has been installed properly.
- 2) Turn on the power while holding down the SELF button and the self-test begins.
- 3) The self-test prints the current status of the printer including control ROM version.
- 4) After printing the current printer status, the printer wait for the next step after printing the following lines. (The paper signal light keeps blinking.)

**Press the button continuously with below number,
You can enter the mode what you want.
(Procedure off If no touching over 2 sec)**

- 1: Memory switch configuration mode**
- 2: Hexadecimal dump mode**
- 3 or more: End**

- 5) Press the SELF button once for the memory switch configuration mode and twice for the hexadecimal dump mode.
- The self-test ends by pressing the SELF button three times.
 - The self-test automatically ends two seconds after self-test printing without the need for pressing the SELF button

(1) If you select "VMSM Selection"

- ① When entering the memory switch configuration mode, the following message is printed.

**** VMSM Selection ****

0: Exit and reboot printer
1: Print current settings
2: Set Serial Interface
3: Set Print Density
4: Set Print Speed
5: Set Cutting mode
6: Set Print width
7: Factory Reset
8 or more: None

- ② To execute the above function, operate the SELF button as follows.
- Step 1 (selecting desired item): Press the button as many times as the number displayed before each menu to select the desired setting menu.
 - Step 2 (entering setting item): Press and hold the button for 1 second to apply the selected item.
- ③ Execute the "0: Save settings and exit" function to apply the changed settings. When "Save settings and exit" mode is active, the above message will be displayed and the printer will reboot.

***** COMPLETED *****

(2) If you select “hexadecimal dump mode”

- ① When entering the hexadecimal dump mode, the following message is printed.

**Hexadecimal dumping
To terminate hexadecimal dump
press SELF button three times**

- ② Execute the program to send data to the printer.
Printing is conducted by dividing all data into two rows.
The first row indicates hexadecimal code.
The second row indicates ASCII characters corresponding to the hexadecimal code.



```

1B 21 00 1B 26 02 40 40 40 40    .! . . & . @ @ @ @
02 0D 1B 44 0A 14 1E 28 28 28    . . . D . . . . ( ( (
00 01 0A 41 0D 42 0A 43 43 43    . . . A . B . C C C
    
```

- When there is no corresponding ASCII code, a period (.) is printed.
- All commands cannot be used in the state of hexadecimal printing mode.

- ③ When the hexadecimal dump completes, press SELF button three times.
- ④ As the hexadecimal dump code ends, the following message is printed.

Hexadecimal Dump Completed.

 Note	With self-test, you can check that the printer is operating normally, the print quality, ROM version, and memory switch setting.
 Caution	<ul style="list-style-type: none"> - The self-test automatically ends two seconds after self-test printing without the need for pressing the SELF button. - When the “0: Save settings and exit” function is not executed in the memory switch configuration mode, setting information is not saved in the printer. - When it is impossible to enter the hexadecimal dump mode, please contact the customer center.

3. Automatic calibration of Black-mark sensor

A printer is designed to detect most of Black-mark types. However it might fail to detect few special cases. In the event of such a failure, we would like you to do as follows

- 1) Turn off the printer and remove a paper roll.
- 2) Press 'Self button', while turning on the printer.
 - Hold down 'Self button' till both Paper LED and Error LED are blinking.
 - Both LED blinking indicates that 'Automatic Black-mark recognition mode' is on.
- 3) Open the cover and load a paper roll then close the cover.
- 4) Black-mark calibration commences.
 - A printer begins with recognizing the gap of each black-mark.
- 5) A printer will be rebooted, after the calibration is successfully done.

**Note**

- Automatic calibration mode works, provided that Black-mark mode is on.
- Necessary conditions for Automatic Black-mark recognition.
 1. Initial Installation
 2. Changing with new paper rolls
 3. In the event, a printer does not stop at the point of a black-mark

4. Cleaning Printer

Paper dust inside the printer may lower the print quality.
In this case clean the printer as follows.

- 1) Open the printer cover and remove the paper currently in use.
- 2) Residue or contamination of printer head should be wiped out by ethanol or IPA.

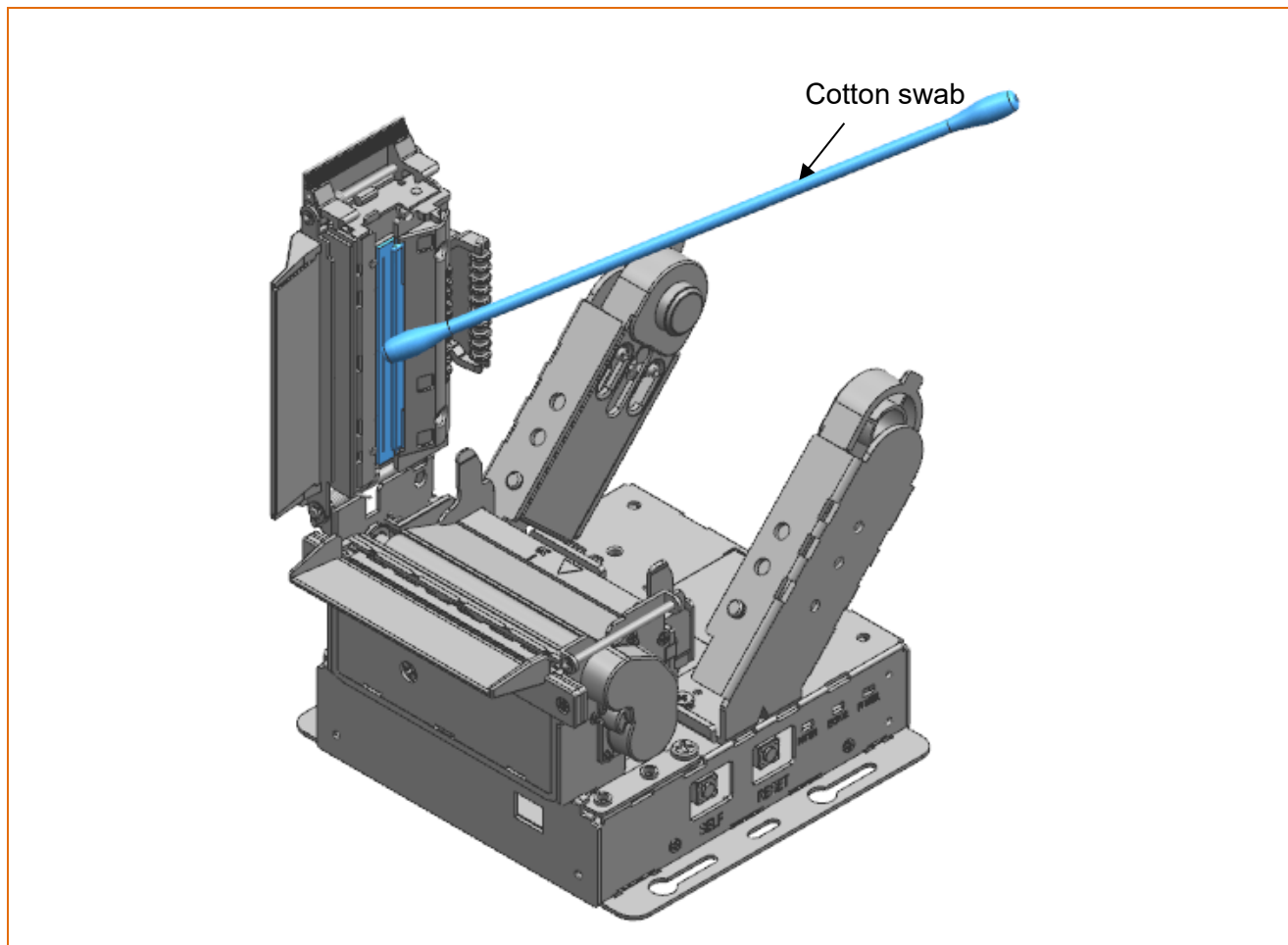

- 3) Clean the paper sensor and paper roller with a cotton swab or a dry cloth.
- 4) Insert a paper roll and close the printer cover.



Caution

When cleaning the printer head, make sure that cleaning solutions such as ethanol or IPA do not penetrate the printer.



Warning

**While the printer is operating, the print-head gets very hot, so turn off the power and let it cool down completely.
The hot print-head can cause serious burns.**



5. Specifications

1) Normal Specifications

Printing Method		Thermal printing		
Dot Density		203 dpi (8dots/mm)		
Paper Width		60mm	58mm	20mm
Printing Width		54mm	48mm	12mm
Printing Speed (Max)		250mm/s	250mm/s	100mm/s
No. of Characters per Line (Default Value)	Font A (12x24)	36characters	32characters	8characters
	Font B (9x17)	48characters	42characters	10characters
	Font C (9x24)	48characters	42characters	10characters
Font Size	Font A(12x24)	1.50 x 3.00mm		
	Font A (9x17)	1.13 x 2.13mm		
	Font A (9x24)	1.13 x 3.00mm		
Number of Character		Alphanumeric Characters: 95		
		Extended Characters: 128 x 37 Page (Including one space page)		
		International Characters: 32		
Barcode	1 Dimension	UPC-A, UPC-E, JAN13(EAN), JAN8(EAN), CODE39, ITF, CODABAR, CODE93, CODE128, GS1-128, GS1 DataBar Omni-direction, Truncated, Limited		
	2 Dimension	PDF417, QR code(model 1/2), Data Matrix , GS1 Databar Stacked, Stacked Omni-directional		
Auto cutter		Full / Partial cut (selectable by command)		
Interface	SERIAL	RS232C compliance		
	USB	V2.0 Full speed compliance		
Receiving Buffer Size		30K bytes		
SMPS Specification	Input Voltage	100~240 VAC		
	Frequency	50/60 Hz		
	Output Voltage	24 VDC		
	Output Current	Continuous: 2.5A, Peak: 11A(@ Min. 0.1ms)		
Environment Condition	Temperature	Operating: -20 ~ 60 °C (*1) Storage: -20 ~ 60 °C		
	Humidity	Operating: 10 ~ 95 % RH Storage: 10 ~ 95 % RH (non-condensing) excluding paper		
Life Span	Printer Head(*2)	100 Km		
	Auto Cutter	1,500,000 cuts		

*1) Printing quality and product life are only guaranteed temperature ranging from 0°C to 40°C. Long-term operation out of range between 0 and 40°C can shorten printer life span.

*2) The specifications were determined based on operation at normal temperature using designated paper on default settings. They are subject to change depending on temperature or printing level.

 Caution	Printing speed may become slightly slower depending on the data transmission speed and the combination of commands.
 Warning	If you do not use an SMPS that meets the above ratings, problems may occur with the product and quality, and we are not responsible for any problems that occur.

2) Paper Specifications

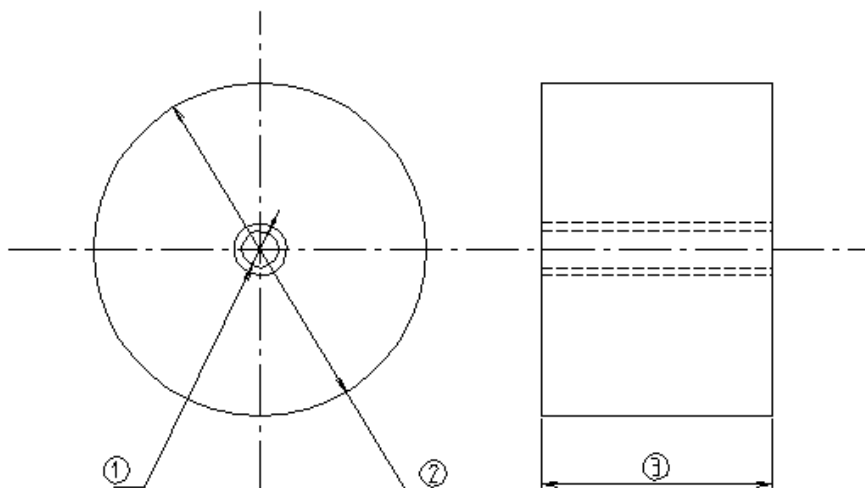

1. Roll Core Inside Diameter (mm)	$\Phi 11_{+3,-0}$ ※ Holder Paper Phi25 (Option Parts) applied: $\Phi 25_{+3,0}$
2. Roll Core Outside Diameter(mm)	$\Phi 18$ (Min)
3. Outer Diameter (mm)	$\Phi 120$ (Max)
4. Width (mm)	$60_{+0,-1}$ / $58_{+0,-1}$ / $20_{+0,-1}$
5. Thickness (mm)	0.05 ~ 0.12

Recommended Papers

- TF50KS-E (Paper Thickness: 65 μ m): Nippon Paper Industries Co., Ltd.
- PD 150R (Paper Thickness: 75 μ m): New Oji Paper Mfg, Co., Ltd.
- PD 160R (Paper Thickness: 75 μ m): New Oji Paper Mfg, Co., Ltd.
- P350 (Paper Thickness: 62 μ m): Kansaki Specialty Paper, Inc. (USA)
- P220AG (Paper Thickness: 65 μ m): Mitsubishi Paper Mills Limited
- P220A (Paper Thickness: 65 μ m): Mitsubishi Paper Mills Limited
- F5041 (Paper Thickness: 65 μ m): Mitsubishi HitecPaper Flensburg GmbH
- P5047 (Paper Thickness: 60 μ m): Mitsubishi Paper Mills Limited

 Caution	<ul style="list-style-type: none"> - Use of papers other than those recommended above may damage TPH or degrade the printing quality and our company is not responsible for the damage caused by non-recommended papers. - If you have to use other products, we recommend that you use papers with a similar level of quality to the recommended ones. - If a sticking phenomenon (a phenomenon where feeding with TPH and paper does not occur) occurs due to the characteristics of the paper, be sure to adjust the printing density and speed.
--	---

3) External Size
 (1) BK3-21 (Horizontal Type)

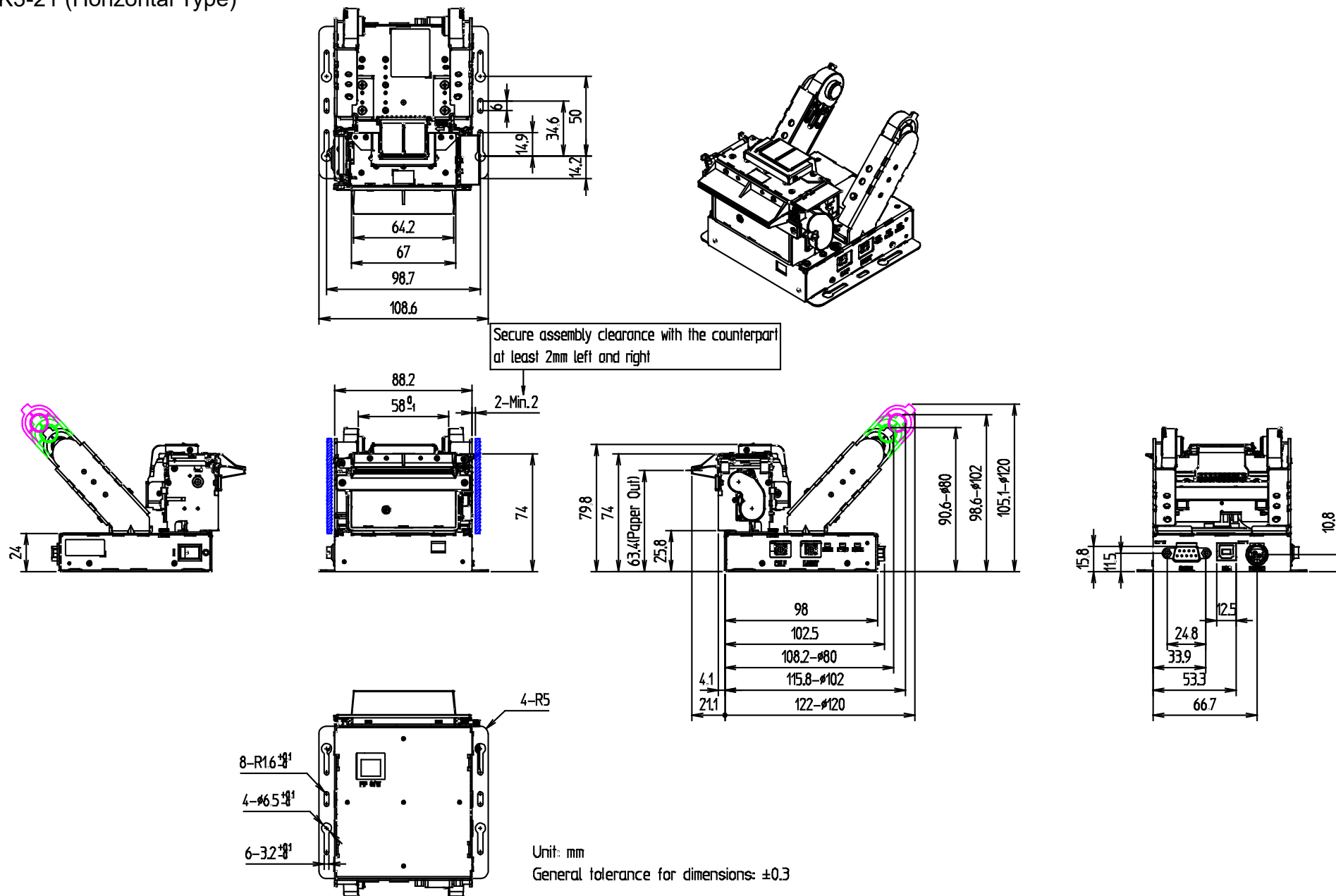

(2) BK3-21V (Vertical Type)

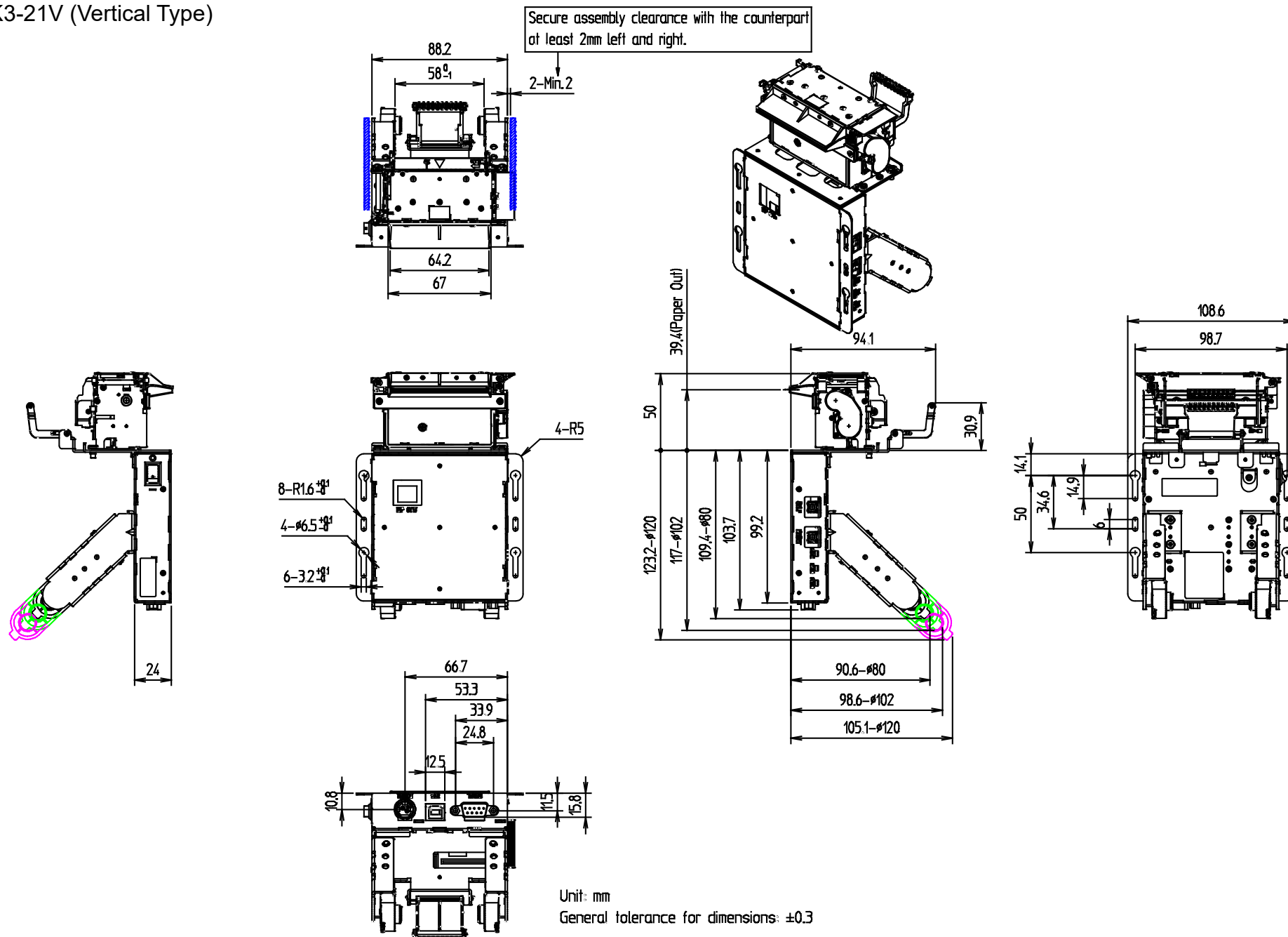

Copyright

© BIXOLON Co., Ltd. All rights reserved.

This user manual and all property of the product are protected under copyright law. It is strictly prohibited to copy, store, and transmit the whole or any part of the manual and any property of the product without the prior written approval of BIXOLON Co., Ltd. The information contained herein is designed only for use with this BIXOLON product. BIXOLON is not responsible for any direct or indirect damages, arising from or related to use of this information.

- The BIXOLON logo is the registered trademark of BIXOLON Co., Ltd.
- All other brand or product names are trademarks of their respective companies or organizations.

BIXOLON maintains ongoing efforts to enhance and upgrade the functions and quality of all our products.

In the following, product specifications and/or user manual content may be changed without prior notice.

Caution

Some semiconductor devices are easily damaged by static electricity. You should turn the printer "OFF", before you connect or remove the cables on the rear side, in order to guard the printer against the static electricity. If the printer is damaged by the static electricity, you should turn the printer "OFF".

Revision history

Rev.	Date	Page	Description
1.00	01.15.20	-	New
1.01	09.17.21	31,32	1. Added the dimension of counterpart assembly space.
1.02	07.06.22	20 30	1. Added Width Adjustment Parts and caution. 2. Added Holder Paper Phi25 (Option Parts).