



DEFENDER® 6000

Extreme Washdown Bench Scales



EasyConnect



Advanced IP68/IP69K Washdown Base

The Defender 6000 Series Extreme Washdown Base is specifically designed for food, chemical and pharmaceutical applications, including production and packaging. Defender 6000 handles the most demanding applications with 316 stainless steel platform and frame, and hermetically-sealed stainless steel IP69K load cell. Defender 6000 meets metrological approvals, NSF listing, and supporting HACCP systems.

Unique Features Include:

- Defender 6000 stands up to harsh cleaning in processing and packaging environments with IP68 immersion/ IP69K washdown protection, 316 stainless steel construction and hermetically-sealed load cell.
- The Defender 6000 bases are equipped with an EasyConnect cable, which allows instant configuration with Defender 5000 and 6000 indicators, speeding installation.
- Durable Defender 6000 is NSF certified, supporting HACCP systems with a 316 stainless steel base providing corrosion protection in food, chemical processing, and packaging.

DEFENDER® 6000 *Extreme Washdown Bases*

Specifications

MODEL	i-D3K1S	i-D6K1S	i-D15K1R	i-D30K1R	i-D60K1L	i-D150K1L
Capacity x Default Readability	3 kg x 0.5 g	6 kg x 0.5 g	15 kg x 1 g	30 kg x 2 g	60 kg x 5 g	150 kg x 10 g
Capacity x Certified/Approved Readability	3 kg x 1 g	6 kg x 2 g	15 kg x 5 g	30 kg x 10 g	60 kg x 20 g	150 kg x 50 g
Safe Overload Capacity	150% of capacity					
Base Construction	316 stainless steel top and bottom frame, hermetically sealed IP68/IP69K stainless steel loadcell				316 stainless steel removable weighing platform with 316 stainless steel frame, hermetically sealed IP68/IP69K stainless steel loadcell	
Linearity/Repeatability	±2d					
Load Cell Capacity	10 kg	10 kg	20 kg	50 kg	100 kg	200 kg
Load Cell Cable	0.5 m L x 6-wire				1 m L x 6-wire	
Load Cell Type	350 Ohm, stainless steel, single point					
Load Cell Excitation	3.3-15V DC/AC					
Load Cell Rated Output	2mV/V					
Load Cell Protection	IP68/IP69K					
Base Dimensions (A x B x C x D)	250 x 250 x 106 x - mm		300 x 300 x 106 x - mm		500 x 400 x 137 x 80 mm	
Shipping Dimensions (L x W x H)	490 x 450 x 380 mm				1,000 x 690 x 250 mm	
Approx. Net Weight	5.8 kg		7 kg		15.6 kg	16.8 kg
Approx. Shipping Weight	8 kg		9 kg		28 kg	30 kg

Outline Dimensions

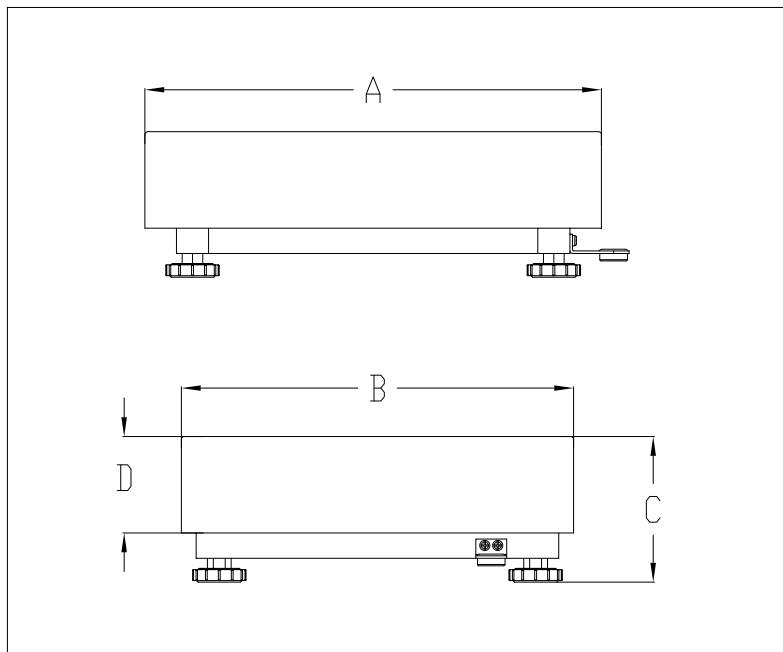

Other Standard Features & Equipment

150% overload capacity protection, open design to minimize build-up and support easy cleaning, non-slip adjustable rubber feet.

Compliance

- **Metrology:** Load Cell: OIML (R60/2000-DE1-06.02, R60/2000-NL1-12.50); EN45501 (D09-06.20, TC7648). Platforms: NTEP (CC 20-064); MC (AM-6154) Class III
- **Food Safety:** ANSI/NSF 169
- **Ingress Protection:** IEC 60529 – IP68, DIN 40050 – IP69K
- **Compliance Marks:** CE
- **Other:** WEEE, RoHS

Accessories

Wheel kit SS Defender Series	30616409
LC Extension Cable, 9 meters	30424409
Column Kit 260 mm 316 SS.....	30572908
Column Kit 670 mm 316 SS.....	30572909
Front Mounting kit 316 SS i-DT61PW.....	30626654
Pan 305x305 mm in 304 SS	30427798
Pan 254x254 mm 304 SS	30427799
Cable Kit Extension for base	30429931

OHAUS Europe GmbH

Heuwinkelstrasse 3,
8606 Nänikon,
Switzerland

e-mail: ssc@ohaus.com

Tel: 0041 22 567 53 19

e-mail: tsc@ohaus.com

Tel: 0041 22 567 53 20

www.ohaus.com

The management system governing the manufacture of this product is ISO 9001:2015 certified.

